

# INSTALLATION INSTRUCTIONS

## C-2345-L, Multi Range Mini Split-Core 4-20mA Output



### DANGER

**Failure to follow these instructions will result in death or serious injury.**



Hazard of electrical shock, explosion, and arc flash

- Follow ALL requirements in NFPA 70E for safe work practices and for Personal Protective Equipment (USA) and other applicable local codes when installing this product
- Only qualified electrical personnel should install this product.
- Read, understand, and follow all instructions thoroughly
- Install only on insulated conductors
- Lock out and tag out all power sources prior to installation. Use properly rated voltage sensing instrument to determine no voltage is present



### WARNING

**Failure to follow these instructions could result in death or serious injury.**



Automated equipment may start without warning

- Equipment monitored/operated by this device may start without warning. Keep clear of apparatus at all times

### IMPORTANT WARNINGS

- Only qualified trade installers should install this product
- This product is not intended for life-safety applications
- Do not install in hazardous or classified locations
- The installer is responsible for all applicable codes
- This product must be installed in a suitable electrical enclosure

## INSTALLATION



Disconnect, lock out and tag out all power supplies during installation

1. Determine mounting location for the sensor near the conductor to be monitored. The sensor should be located AT LEAST 1/2" from any uninsulated conductor.
2. Sensor features a flexible iris which allows the sensor to hang on the conductor if local codes permit. A bracket is included for screw mounting or attaching to DIN rail. For screw mounting, drill two 3/32" pilot holes using the bracket as a template; ensure no drill shavings are present in enclosure. Attach bracket with screws provided.
3. Clamp sensor around INSULATED CONDUCTOR ONLY, 600VAC MAX to be monitored.
4. Snap the sensor into the mounting bracket.
5. Wire the output of the sensor to a control panel analog input. Sensor is loop-powered. 12 to 30vdc excitation required. Tighten terminals to 3.5 in-lb.

## SETUP

1. Sensor is factory calibrated to three ranges. No field calibration is required.
2. Move selector switch to desired factory calibrated range setting. Selected range should be greater than the maximum motor current.

## WIRING EXAMPLE

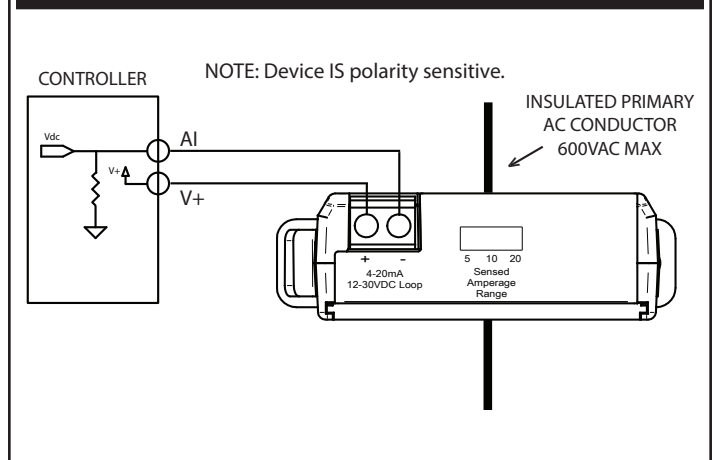

### PRODUCT APPLICATION LIMITATION:

Senva products are not designed for life or safety applications. Senva products are not intended for use in critical applications such as nuclear facilities, human implantable device or life support. Senva is not liable, in whole or in part, for any claims or damages arising from such uses.

152-0266-0B



senva.com 1-866-660-8864 (F)1-503-296-2529 9290 SW Nimbus Ave. Beaverton Oregon 97008

## DIMENSIONS

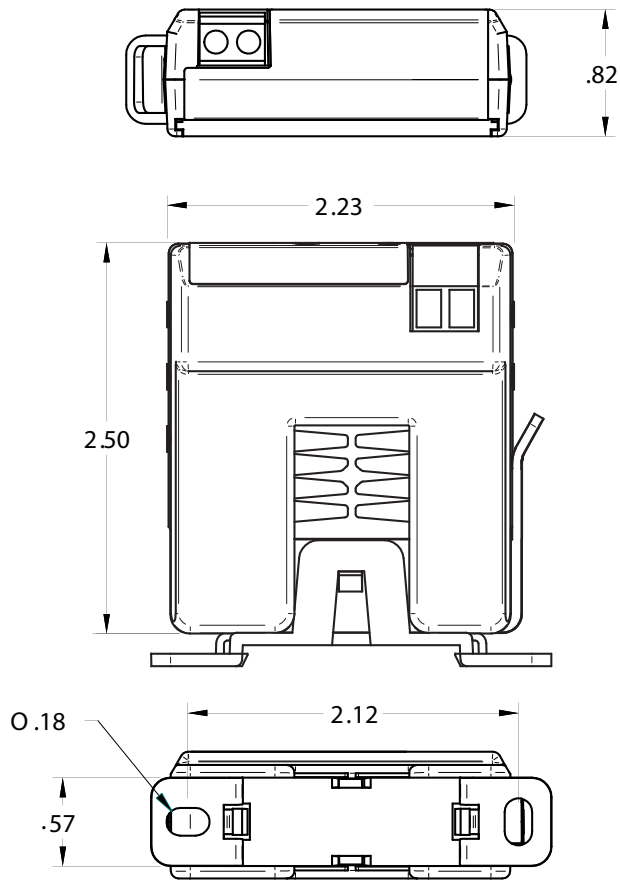

## OPERATION

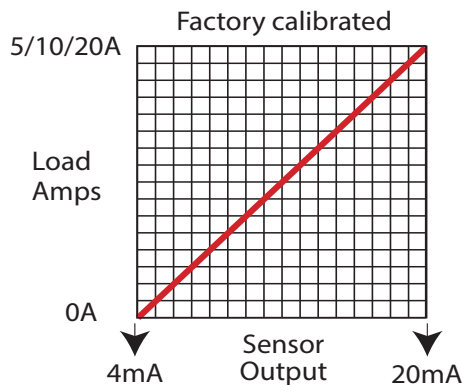

The C-2345-L provides a 4-20mA output signal proportional to monitored current. A switch allows field selection of 5, 10, or 20 amps full-scale.

### Typical load status applications include:

- Load trending
- Monitoring process motors and pumps
- Heater current monitoring

## TECH TIPS

### On low current loads, wrap sensor multiple times to increase sensitivity

CAUTION: Do not exceed sensor maximum current. The current detected by the sensor will increase 1X with each wrap.

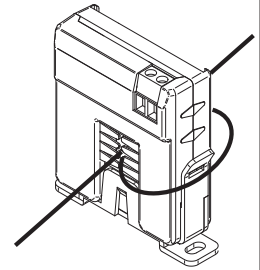

### To monitor loads greater than the current sensor maximum rating

Use a properly rated 5A CT as shown below



### CAUTION!

5A CTs can present hazardous voltages. Install CTs in accordance with manufacturers instructions. Terminate the CT secondary wiring before energizing primary conductor.

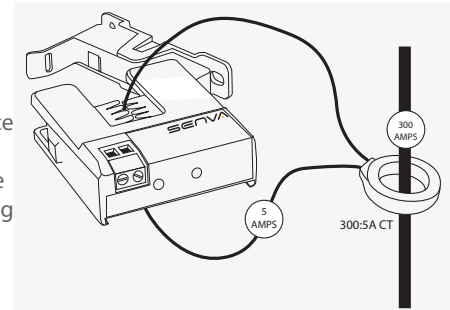

Remember to consider the ratio of the CT secondary to the sensor full-scale range to determine sensor output. Example: A 300:5A CT will produce 5 amps max, which is 1/4th of the 20 amp full-scale range of the C-2345-L. Applying this ratio (1/4) to the 16mA output range (20mA - 4mA) gives a 4.00mA signal change for a reading of 8.00mA at 300 A.

## Troubleshooting

| Symptom                    | Causes                                       | Remedy   |
|----------------------------|--|--|
| Sensor output is over 20mA | Amperage is above factory calibrated maximum | See Tech Tip for monitoring loads greater than current sensor maximum rating |
| No output current          | No excitation voltage<br>Backward wiring     | Check excitation voltage<br>Check polarity                                   |
| Wrong output current       | Incorrect scaling                            | Verify controller scaling  |

Maximum surrounding air ambient, 60 ° C. For use in Pollution Degree 2 Environment.

| Part Number        | C-2345-L  |
|--------------------|---|
| Amperage Range     | Switch selectable 5/10/20 amps (200A Max.)  |
| Output Type        | 4-20mA, loop powered  |
| Accuracy           | +/-2% F.S. over 10 to 100% range  |
| Temperature Rating | -15~60 ° C  |
| Insulation Class   | 600V RMS. For use on insulated conductors only!<br>Use minimum 75 ° C insulated conductor |
| Sensor Power       | 12 to 30VDC Max.  |
| Frequency Range    | 50/60Hz   |
| Dimensions (LxWxH) | 2.94" x 2.23" x 0.82" (1.4" H with optional relay module)                                 |
| Sensor Aperture    | 0.75"   |